

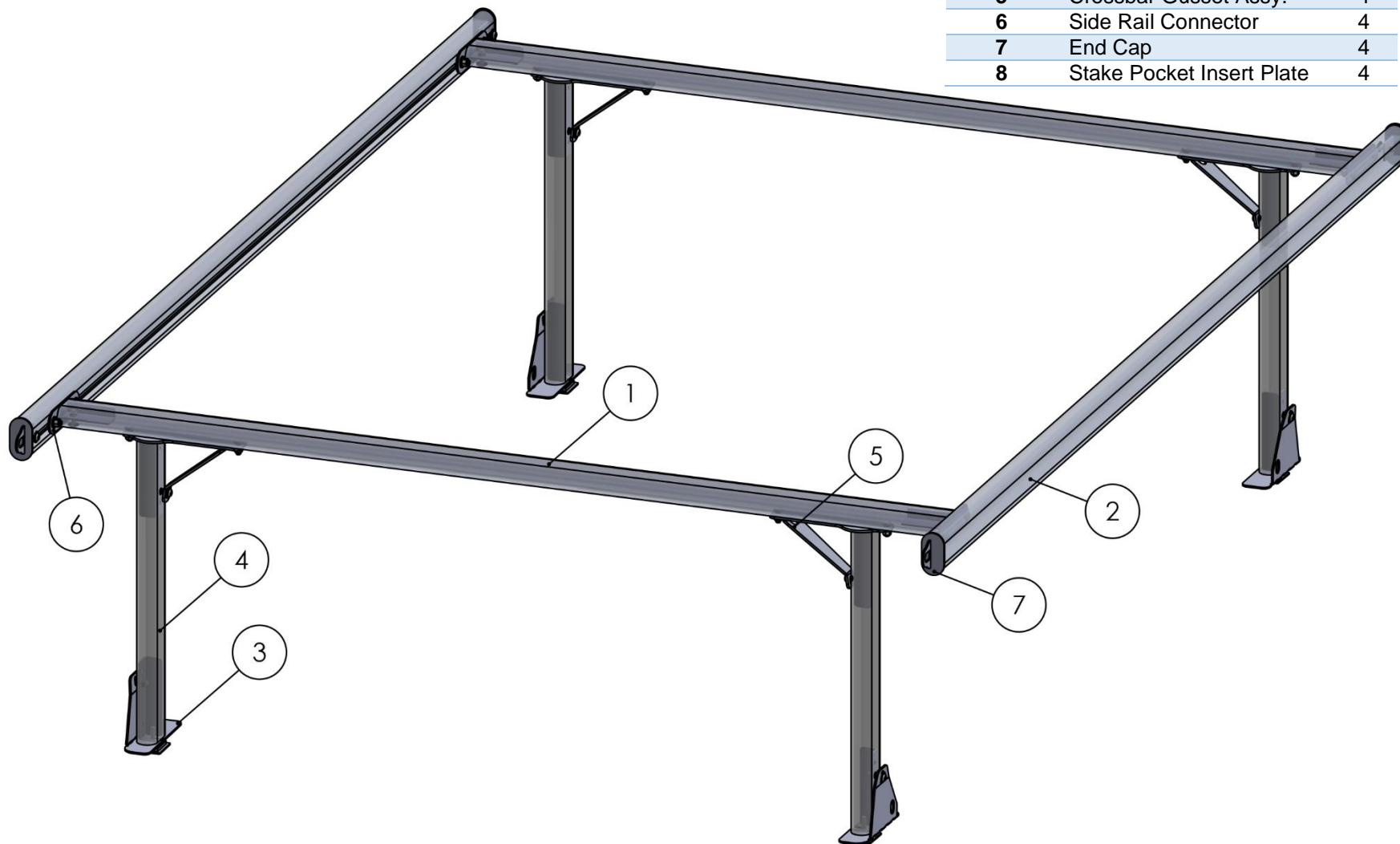

SCHOONER WIDE RACK (FORD / DODGE)

MADE IN THE USA

Item No.	Description	Qty.
1	Crossbar	2
2	Side Rail	2
3	Base	4
4	Leg	4
5	Crossbar Gusset Assy.	4
6	Side Rail Connector	4
7	End Cap	4
8	Stake Pocket Insert Plate	4





SCHOONER WIDE RACK (FORD / DODGE)

MADE IN THE USA

Item NO.	Description	Qty.
8	Stake Pocket Insert Plate	4
9	3/8" – 16 x 1.25" Button Head Screw	16
10	3/8" – 16 x 1" Carriage Bolt	16
11	3/8" – 16 x 1.75" Carriage Bolt	4
12	3/8" – 16 Nylon Lock Nut	20
13	3/8" X 7/8" Metal Washer	36
14	Allen Wrench	1

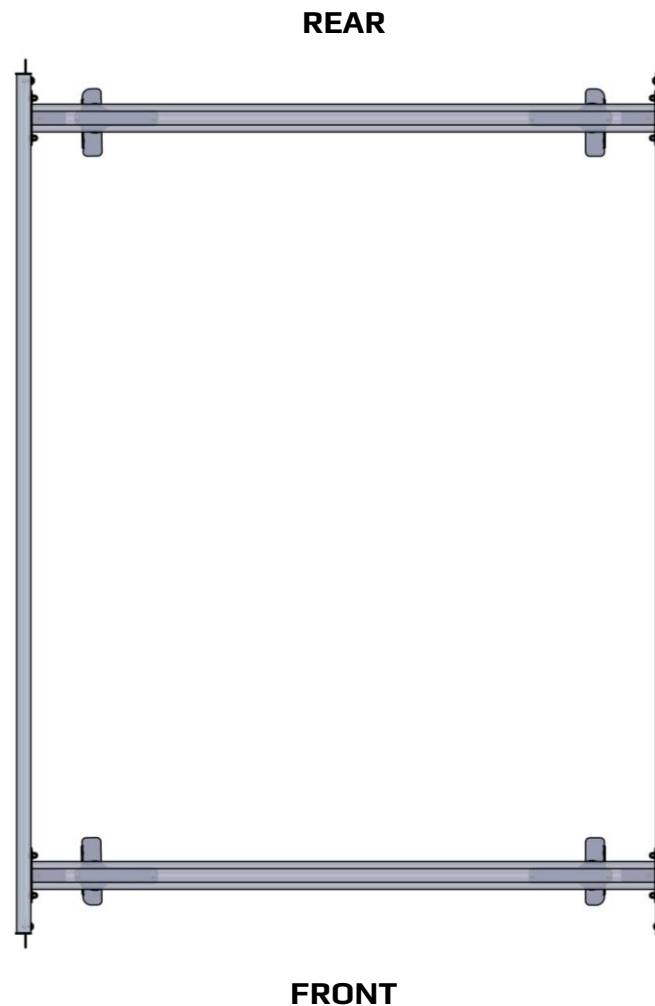
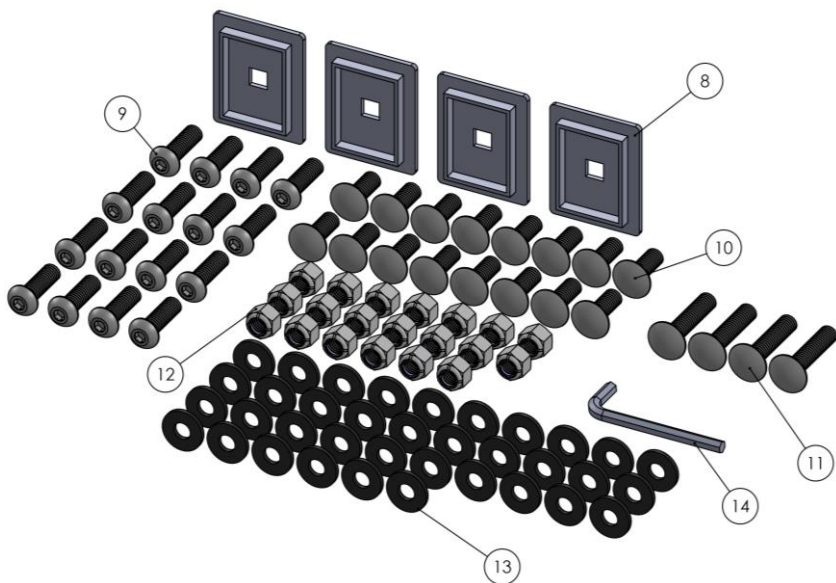

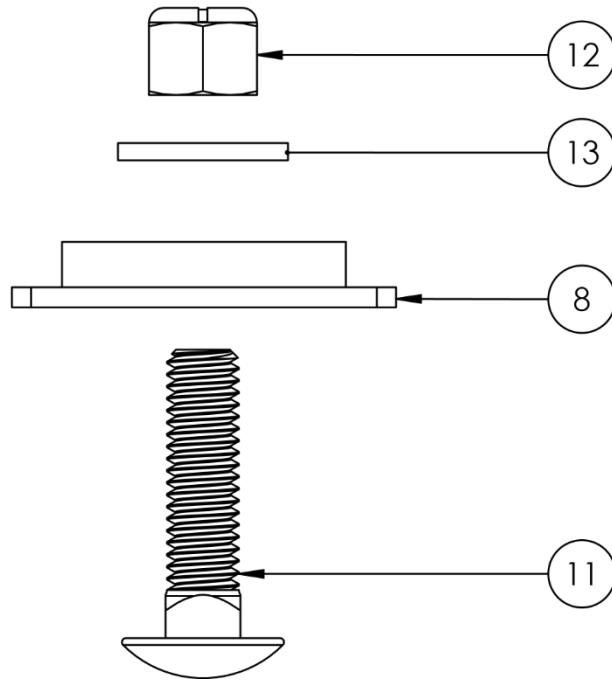

Figure 1

NOTICE: Ensure that the larger portion of the plate is fully seated inside the pocket and that the smaller raised portion of the plate is seated within the profile of the rectangular hole. It is critical that the raised portion fits within this profile and that no edge of the bottom plate is visible from above – even when jimmied. This will prevent the carriage bolt and the plate from spinning, sliding or coming apart. If you cannot seat the plate in accordance with these instructions, STOP, and contact customer service at 1-951-271-3498 before proceeding with installation.

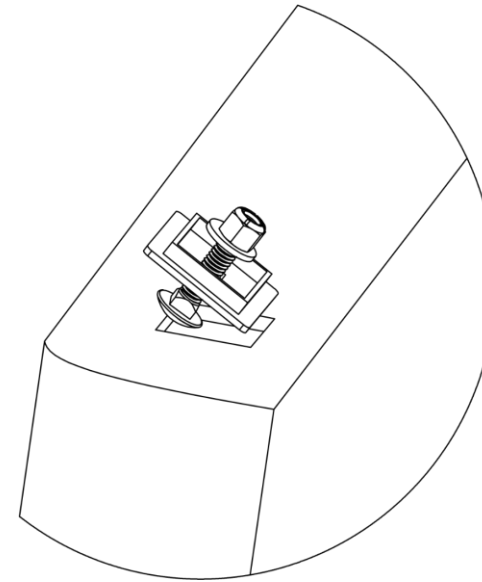

Figure 2

1. **Install the Stake Pocket Insert Plates.** To install the Bases (Item No. 3) you must first install the Stake Pocket Insert Plates (Item No. 8). The parts of this bolt assembly will be put together in the order as shown in Figure 1. Combine these parts but allow space for the Base (Item No. 3) by leaving the Lock Nut (Item No. 12) at the end of the Carriage Bolt (Item No. 11). Once this bolt assembly has been put together, insert the Stake Pocket Insert Plate (Item No. 8) into your truck's stake pocket by tilting the plate diagonally.

2. **Install the Rack Bases.** Examine the Bases (Item No. 3) and notice an oval shaped eyelet on its face. These eyelets should be positioned so that they face each other as shown in Figure 3. To install the base, place it on the truck's bedrail and position it so that the opening found on the bottom of the base is aligned with the bolt projecting up out of the stake pocket. As shown in Figure 4, slide the Base forward so that its bottom can be clasped between the Carriage Bolt (Item No. 11), the Metal Washer (Item No. 13) and the Lock Nut (Item No. 12). Once the Base has been pushed forward, use a wrench to tighten the assembly until the washer and lock nut are in contact with the bottom of the base. **DON'T forget to apply a little grease to the screws before tightening or it may be hard to remove the nuts later.**

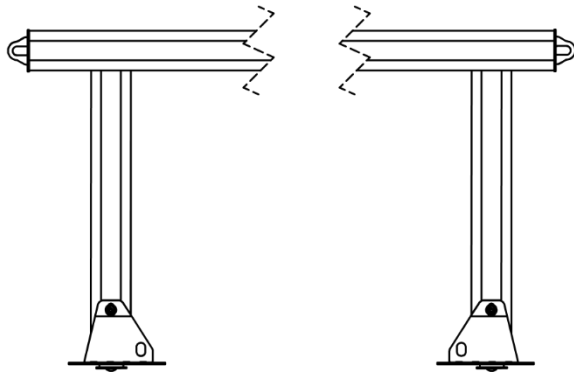

Figure 3

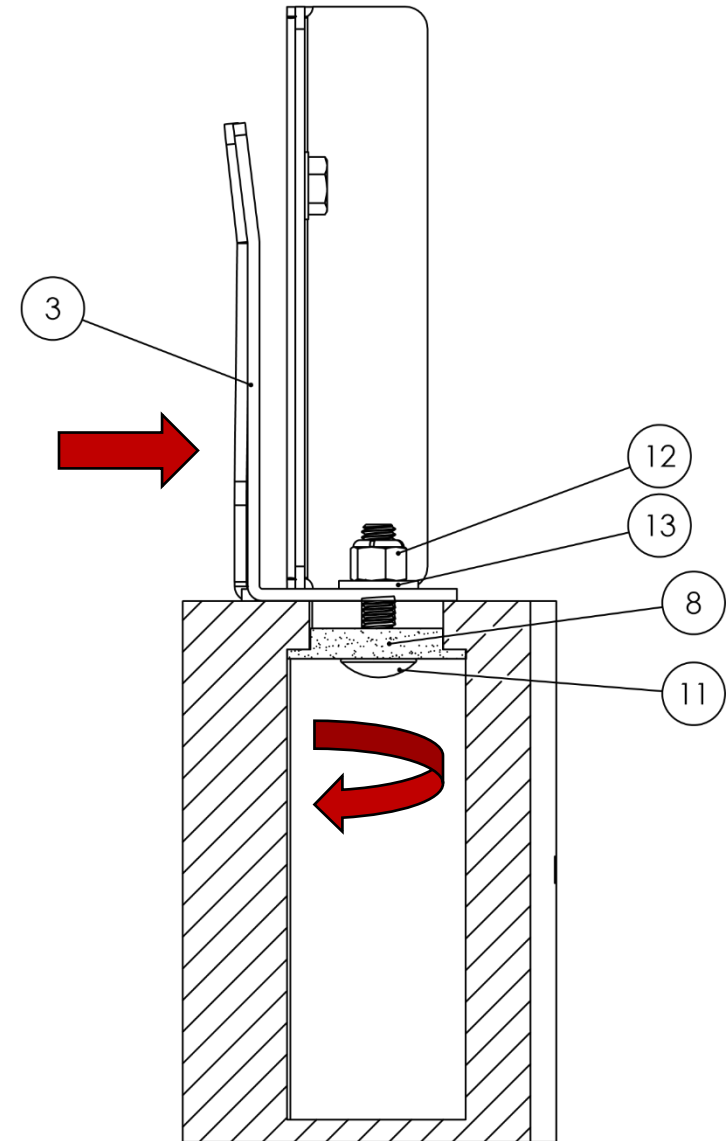

Figure 4

3. **Attach the Legs to the Bases.** Examine the Legs (Item No. 4) and locate the pre-drilled holes on the outside of each leg. As shown in Figure 5, slide the leg down and align it so that its hole matches with the holes found on the Base (Item No. 3).

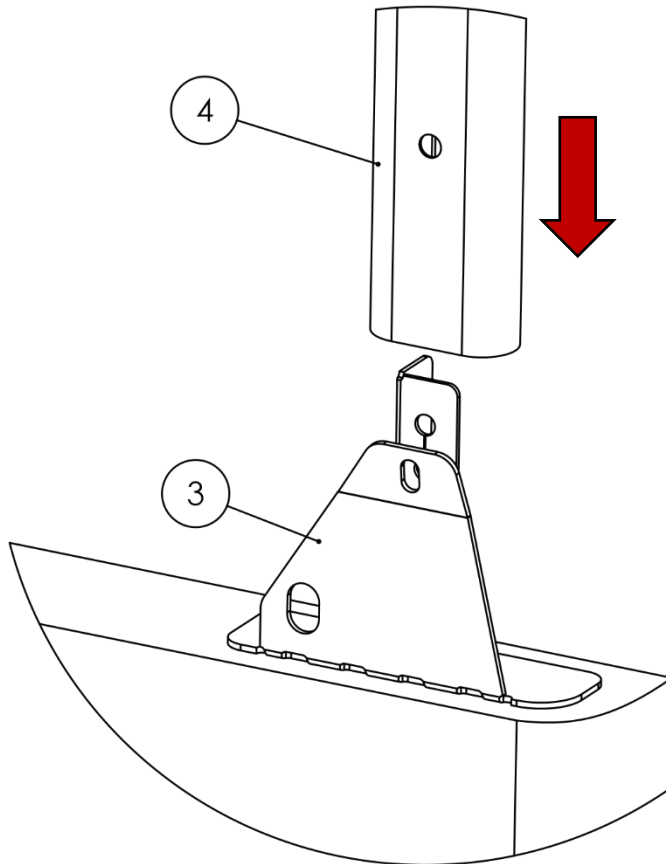

Figure 5

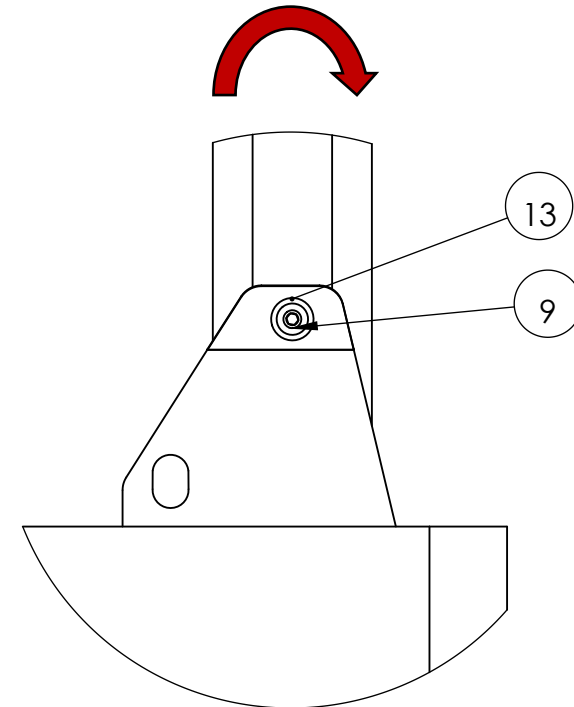

Figure 6

3. Secure the parts together by threading a 1.25" Button Head Cap Screw (Item No. 9) with a Washer (Item No. 13) into the concentric holes. Lightly tighten the screws for now so that you can align the rack once the Crossbars are mounted.

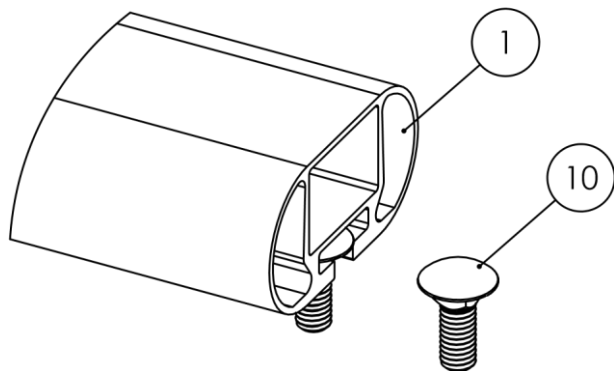

Figure 7

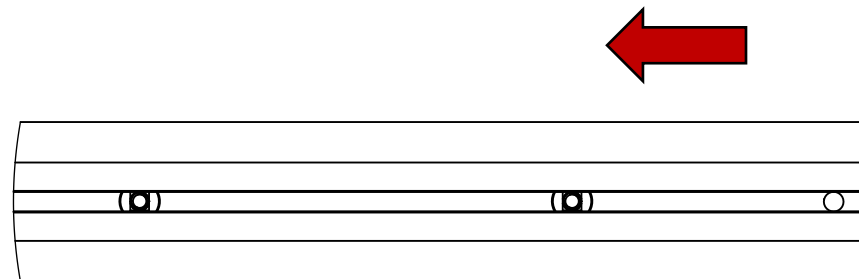

Figure 8

4. **Insert the Carriage Bolts into the slotted Crossbar.** Examine the Crossbars (Item No. 1) and notice that a slot runs down the length of each Crossbar. Insert (2) 1" Carriage Bolts (Item No. 10) into each end of each Crossbar – a total of 8 times. For the moment, arrange the Carriage Bolts about 9" apart as shown in Figure 8.

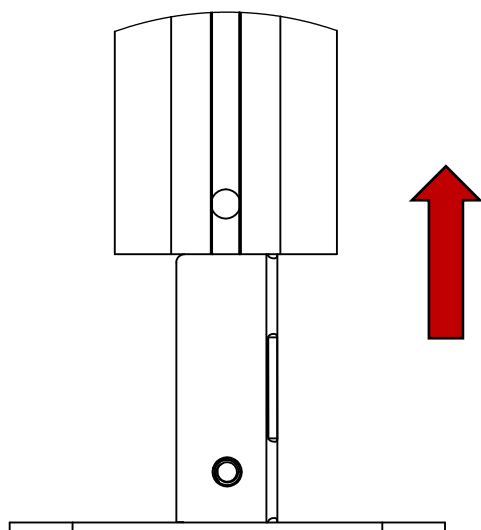

Figure 9

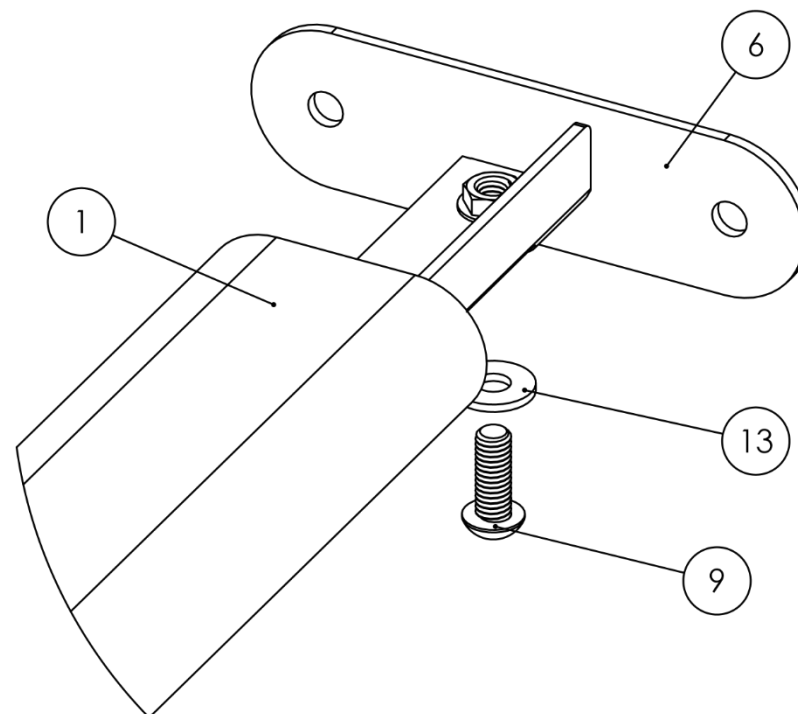

Figure 10

5. **Install the Side Rail Connectors to the Crossbars.** Slide a Side Rail Connector (Item No. 6) into the end of each Crossbar (Item No. 1). Once inserted, match the Crossbar's pre-drilled hole with the Connector's threaded hole. As shown in Figure 10, secure each Side Rail Connector by threading a 1.25" Button Head Cap Screw (Item No. 9) and a Metal Washer (Item No. 13) into these holes.

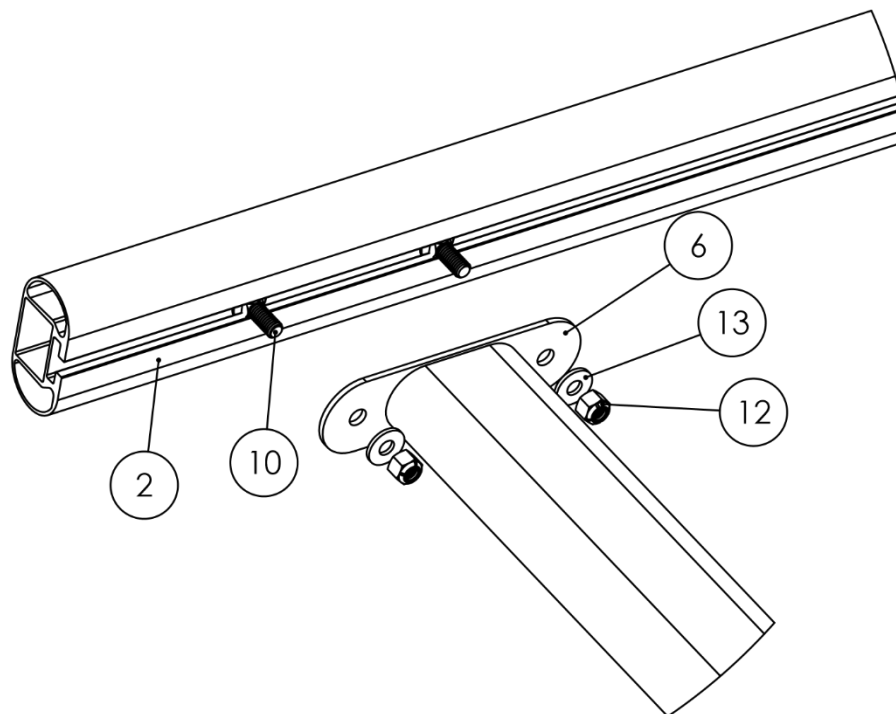

Figure 11

6. **Attach the Side Rails to the Crossbars.** Examine the Side Rails (Item No. 2) and notice a slot (channel) running the length of the inner side. Lay the Side Rails on the ground and slide (2) 1" Carriage Bolts (Item No. 10) into each end – a total of 4 times per Side Rail. Once you have placed the Carriage Bolts at a position relative to the location of the Legs (Item No. 4), hold up a Side Rail and place it against the end of a Crossbar (Item No. 1) in such a way that allows you to complete the attachment as shown in Figure 11. Push the Carriage Bolts through the holes found on the Side Rail Connector (Item No. 6) and fasten each with a Lock Nut (Item No. 12) and Washer (Item No. 13). Complete the process at each Crossbar and Side Rail joint.

7. **Install the End Caps to the Side Rails.** Slide (4) End Caps (Item No. 7) into each end of a Side Rail (Item No. 2). Once inserted, match the Side Rail's pre-drilled hole with the End Cap's threaded hole. As shown in Figure 12, secure each End Cap by threading a 1.25" Button Head Cap Screw (Item No. 9) and a Metal Washer (Item No. 13) into the concentric holes.

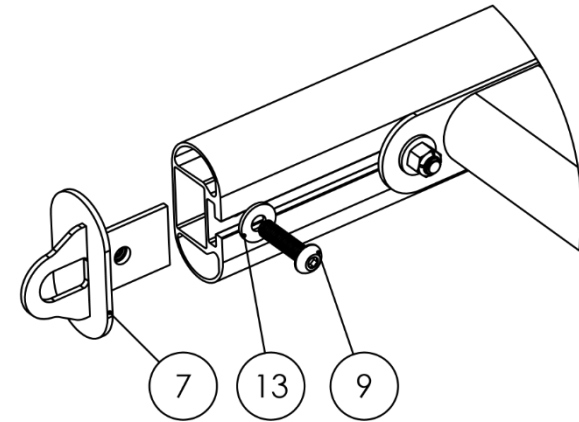

Figure 12

8. **Attach the Crossbar Gussets to the Legs.** Grab the (4) Crossbar Gusset Assemblies (Item No. 5) and notice that their angular projection parallels the inside of the Legs (Item No. 4). As shown in Figure 13, slide this end into the Legs and secure the parts by threading a 1.25" Button Head Cap Screw (Item No. 9) and a Metal Washer (Item No. 13) into the concentric holes.

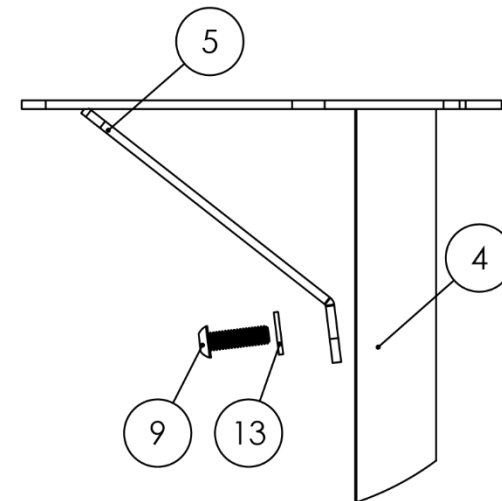

Figure 13

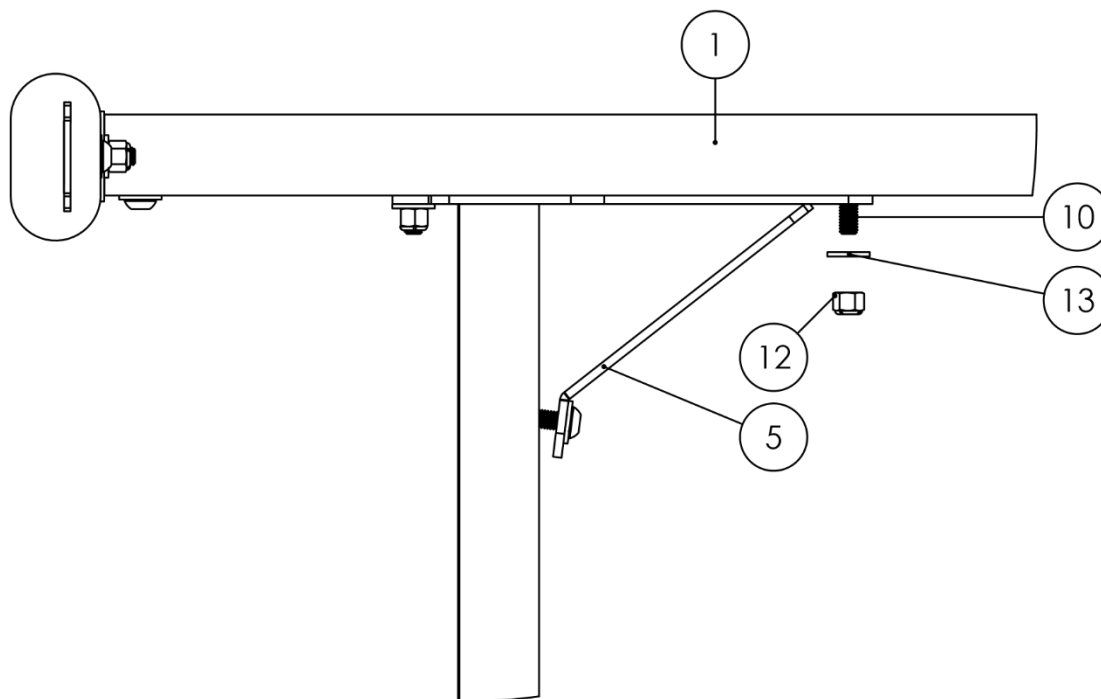

Figure 14

- Install the Crossbars onto the Legs.** To install the newly formed Crossbar (Item No. 1) and Side Rail (Item No. 2) assembly, hold it above the Legs (Item No. 4) so that the ends of the Carriage Bolts (Item No. 10) hang down and align with the holes on the Crossbar Gusset Assembly (Item No. 5). Using a Metal Washer (Item No. 13) and a Nylon Lock Nut (Item No. 12) secure each Leg and Crossbar. Figure 14 shows the bolt assembly as it is required.

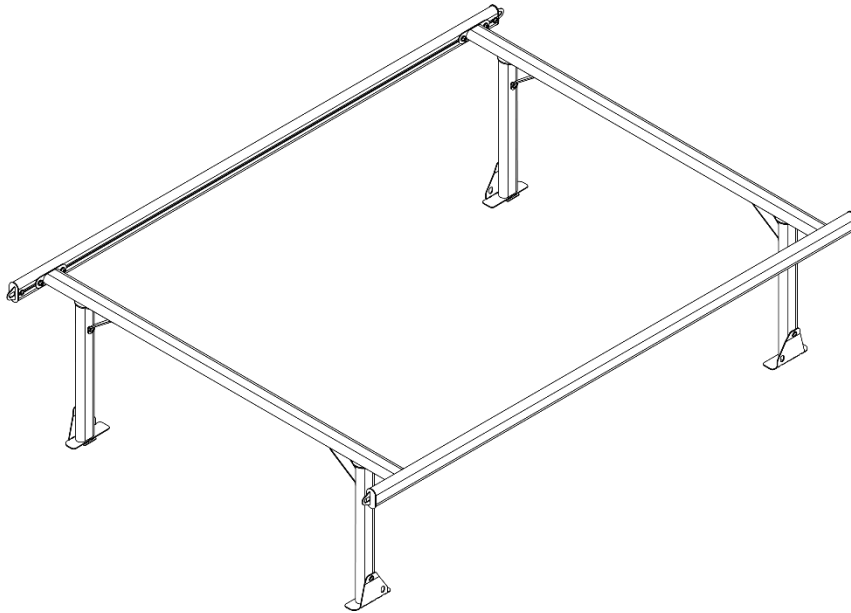

Figure 15

REMEMBER TO BE SAFE: Carrying any load can be hazardous. Avoid roll over. As with all racks, ensure that loads are not top-heavy. Loads should be placed so that the center of mass of the load is no closer than 24" from the sides of the rack. High loads must be transported with GREAT CAUTION to prevent loads from striking low overhead objects and from tipping during turns, abrupt stops, or high winds. Loads extending beyond the rear bumper of the vehicle must be designated with a red flag during daylight or red light during darkness in accordance with the state vehicle code.



Figure 16

- Tighten all screws and nuts on the rack firmly** with the Allen wrench. It is best to tighten each screw with increasing firmness as you move around to various fasteners so that you can check the alignment of the parts. When finished, all fasteners should be firmly tightened but not so firmly that the truck, rack components, or fasteners are stripped or damaged. When completed, the assembly should appear like what is shown above where all members of the rack are held rigidly together. Complete the assembly by applying horizontal pressure to the rack to ensure that the rack's base and the stake pocket components are unable to move. Frequently check the tightness of any threaded parts.